



PXC64-U

DESIGO™ PX

## Automation stations modular model

PXC...-U

- Freely programmable modular automation stations for HVAC and building services.
- Native BACnet automation station with communication via BACnet over Ethernet / IP, LonTalk, or PTP
- BTL label (BACnet communications passed the BTL test)
- High performance and reliable operation
- Comprehensive management and system functions (alarm management, time scheduling, trends, remote management, access protection etc.)
- An Integrated Web server supports generic or graphic Web operation as well as transmission of alarms by e-mail or SMS
- P-bus for connection of external TX-I/O or PTM I/O modules with any data point mix
- Integration platform for subsystems and 3<sup>rd</sup> party systems
- For stand-alone applications or for use within a device or system network
- Supports the following methods of operation:
  - QAX... room units
  - Local or network-compatible operator units
  - PX-WEB (operation via Web browser, touch panel or PDA)

## Functions

These freely programmable automation stations provide the infrastructure for the provision and processing of system-specific and application-specific functions. Apart from the freely programmable control functions these units comprise integrated convenient management functions such as:

- Alarm management with alarm routing throughout the whole network. Three level alarm management (simple, basic and enhanced) with safety control transmission and automatic transmission monitoring
- Time schedulers
- Trend functions
- Remote management functions
- Access protection for the whole network with individually defined user profiles and categories

## Programming language

These automation stations are freely programmable with the D-MAP programming language (follows closely CEN Standard 1131). All function blocks available in libraries are graphically linked with the plant operating programs.

## Communication

BACnet / IP	Communication is via Ethernet with the international standard BACnet protocol. Both peer-to-peer communications with other automation stations and connections to the PXM20-E operator units are supported.
BACnet / LonTalk	The devices communicate via an open LonTalk system in accordance with the international standard BACnet protocol. Both peer-to-peer communications with other automation stations and connections to the PXM20 operator units are supported.
BACnet / PTP	The devices communicate via the public telephone network in accordance with the international standard BACnet protocol.

## Types

Automation stations	Type
Automation station – for TX-I/O modules (up to 200 data points) – for PTM-I/O modules (up to 64 load units *)	PXC64-U
Automation station – for TX-I/O modules (more than 200 data points, see system limits) – for PTM-I/O modules (up to 128 load units *)	PXC128-U
Connecting cable (to connect an operator unit PXM10 or PXM20 and for Firmware download)	PXA-C1
*) 1 load unit = 12.5 mA (see data sheets of the I/O modules PTM1...)	
System controllers	Type
System controller for the integration of DESIGO RXB room controllers and KNX 3 <sup>rd</sup> party devices	PXC00-U + PXA30-K11
System controller for the Integration of M-Bus, Modbus and SCL (up to 100 data points)	PXC00-U + PXA30-RS
(up to 400 data points)	... + PXA30-RS1
(SCL: up to 1000 data points, M- Bus and Modbus: up to 2000)	... + PXA30-RS2

## Compatibility

### Extension modules for automation stations

Function	Module PXA30-...	T	N	NT	W1	W2	W0
	Data sheet	N9261	N9262	N9263	N9264	N9265	N9266
<b>Interfaces</b>							
Ethernet RJ45			X	X	X	X	X
Serial RS232		X		X	X	X	X
<b>Network functions</b>							
Configuration network RJ45			X	X	X	X	X
BACnet / IP operation RJ45			X	X	X	X	X
BACnet / LonTalk operation		X					
PTP Dial-in DTS and X-Works RS232 <sup>1)</sup>		X		X	X	X	X
PPP Remote configuration RS232 <sup>1)</sup>					X	X	X
<b>Remote management</b>							
PTP Dial-in Desigo Insight RS232 <sup>1)</sup>		X		X	X	X	X
PPP via Ethernet RJ45 <sup>1)</sup>					X	X	X
<b>Web-Functions</b>							
Generic web functions					X	X	X <sup>2)</sup>
Graphic web functions						X	X <sup>2)</sup>
Send alarms via SMS (RS232)					X	X	X
Send alarms via E-Mail (RJ45)					X	X	X

<sup>1)</sup> The modem connection can be configured as follows:

- either for Remote management (DI and DTS – or X-WORKS)
- or for remote management PX WEB generic / graphic and Alarming via SMS

<sup>2)</sup> Web functions only for one automation station

### Extension modules for system controllers

Function	Module	PXA30-K11	PXA30-RS	PXA30-RS1	PXA30-RS2
	Data sheet	N9280	N9281	N9281	N9281
<b>Interfaces</b>					
KNX interface		X			
Ethernet RJ45		X			
Serial RS232			X	X	X
Serial RS485			X	X	X
<b>Network functions</b>					
Integration of RXB		X			
Integration of Synco		X			
Integration of KNX 3rd party devices		X			
Integration of M-Bus counters			100 DP	400 DP	2000 DP
Integration of Modbus			100 DP	400 DP	2000 DP
Integration of SCL			100 DP	400 DP	1000 DP

## TX-I/O-Modules

Device	Type	Data sheet
Digital input modules, 8 or 16 I/O points	TXM1.8D, TXM1.16D	CM2N8172
Universal module without / with local override facility and LCD	TXM1.8U TXM1.8U-ML	CM2N8173
Super universal module without / with local override facility and LCD	TXM1.8X TXM1.8U-ML	CM2N8174
Relay module with without / local override facility	TXM1.6R, TXM1.6R-M	CM2N8175
Power supply module 1.2 A, fuse 10A	TXS1.12F10	CM2N8183
Bus connection module, fuse 10A	TXS1.EF10	CM2N8183
P-Bus Interface module with power supply 1.2A, fuse 10A	TXB1.P-BUS	CM2N8180

## PTM-I/O-Modules

Device	Type	Data sheet
I/O modules with basic functions measuring, signalling, switching and controlling	PTM1...	8111 ... 8171
I/O OPEN modules for pumps	PTM5...	866x
I/O OPEN modules	PTM1...,PTE	978x

## Operation

There are various options for operation of the PXC...U automation stations:

- **QAX... room unit** connected to the PPS2 interface. A **maximum** of five room units QAX... (not QAX5...) can be connected. Details on the PPS2 communication are described in the DESIGO Technical principles manual (chapter "I/O blocks", section "PPS2 addressing").
- **Local PXM10 operator unit**, either plugged into the automation station or connected via PXA-C1 cable
- **Network-compatible PXM20 operator unit** (BACnet / LonTalk) for operation of the local automation station or an automation station in a network, either plugged into the automation station, or connected via PXA-C1 cable
- **Network-compatible PXM20-E operator unit** (BACnet / IP) for operation of the local automation station or an automation station in a network, either plugged into the automation station, or connected to the Ethernet network or an Ethernet switch.
- **PX-WEB:** The PXA30-W... extension module is used to activate the Web server, allowing operation with a Web browser, a touch panel or a PDA. The transfer of alarms via SMS or e-mail can be configured in the automation station.

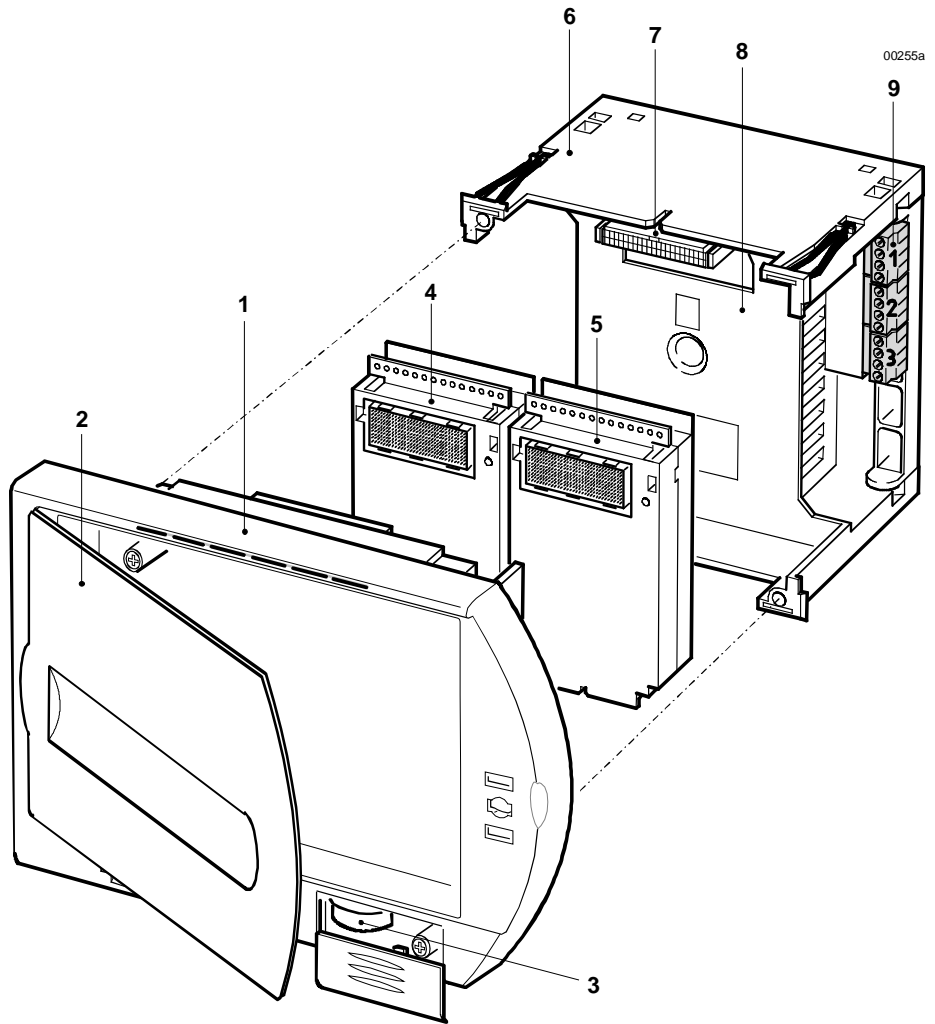

1	Plug-in unit
2	Front cover (a PXM... operator unit can be fitted instead of the front cover)
3	Battery
4/5	Extension modules
6	Device socket
7	Plug-in connection for automation station for device supply and bus electronics
8	Housing with pcb for device supply
9	Plug-in terminal blocks with reversible support bar (here used for wall mounting)

**LED indicators**

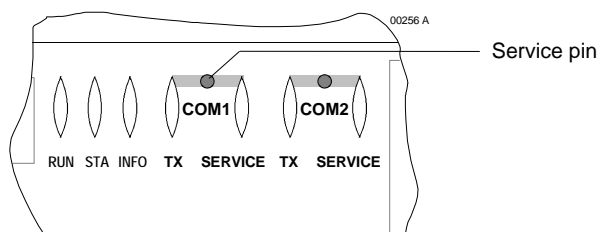

Concerned	LED	Color	Status	Function
Automation station	RUN	Green	Continuously off	No supply
		Red	Continuously on	Supply OK, firmware OK
			Continuously on	RESET key pressed
	STATUS	Red	Continuously off	Normal operation
			Continuously on	Hardware fault detected during self-test or automation station in "coma" operating state
			Quick flashes	No validly licensed firmware
	INFO	Red		Freely programmable
Data traffic LONWORKS bus	TX COM1	Yellow	Flashing	Data traffic on LONWORKS bus
	COM2	Yellow		Inactive
	SERVICE COM1	Red	Continuously off	LONWORKS node is configured
			Flashing	LONWORKS node is not configured
			Flashing acc. to wink command pattern *)	Physical identification of automation station after receiving wink command
			Continuously on	LONWORKS chip defective or service key was pressed again
	COM2	Red		Inactive
Data traffic Ethernet / IP (PXA30-N..., PXA30-W...)	TX COM1	Yellow		Inactive
	COM2	Yellow	Flashing	Sends Ethernet data
	SERVICE COM1	Red		Inactive
	COM2	Red	Continuously off	Ethernet OK
			Flashing slowly	IP address not configured
			Continuously on	No link pulse

\*) Wink command rhythm pattern:

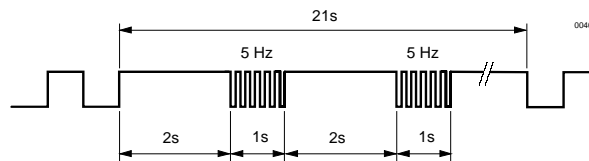

## Mounting instructions

The modular automation stations are particularly suitable for control panel front mounting as well as flush-panel and wall mounting.

For control panel front mounting the device socket is held in place by clamps at all four corners (no tools required for mounting). The upper housing is fixed to the device socket with two screws.

For flush panel mounting the plug-in terminal blocks can be repositioned whilst at the same time reversing the support bars to enable front access. The support bars absorb the screw force and also provide the means of fixing the device to the wall.

Instead of the front cover a PXM... operator unit can be fitted on the modular automation station.

Note For **PXM20-E** mounting (ethernet cable) see the mounting instructions delivered with the operator unit!



### Note!

- Insert the **PXA30... extension module** fully into its socket (to a depth of 1.5 mm), using slight force. Then **check that the plug is safely snapped on** to ensure safe and smooth functioning.
- **Do not touch** the connector pins (electrostatic discharge)

In order to prevent equipment damage and/or personal injuries always follow local safety regulations and the required safety standards.



### Caution!

**Electronic parts may be damaged if the upper housing is inserted or disconnected with the supply voltage switched on (hot plugging).**

### Loading plant operating program

Download the plant operating program to the automation station with the PX Design tool in the DESIGO TOOLSET, locally via the RJ45 connector of the AS or via the LONWORKS bus.

### Setting parameters and configurations

Use the PX Design tool in the DESIGO TOOLSET for setting the control parameters and the configuration data. Data visible in the network can also be changed with the PXM... operator unit.

### Wiring test

It is possible to test field devices and the wiring as soon as the power supply is connected, without first downloading the plant operating program. The test is carried out with a PXM20 or PXM20-E operator unit.

### Network connection

The network addresses are configured with the DESIGO TOOLSET. In order to provide a unique identification in the LONWORKS network press the service pin with a sharp implement (COM1 on the front, see page 4) or send a wink command to the relevant automation station (service LED flashes).

### Service functions

Three service buttons are provide under the front cover:

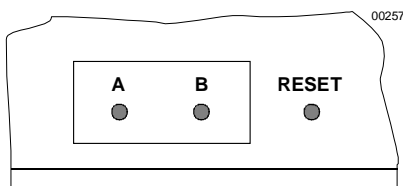

<b>A</b> <b>Force</b> <b>Firmware</b> <b>Download</b>	Connected to LONWORKS - Bus	If this key is pressed during a restart (Power-fail) the current D-MAP program is deleted from the FLASH. The automation station waits a short while for the signal to activate the FWLoader and then starts the automation station..
	Connected to Ethernet / IP	If this key is pressed for >5 s, the automation station waits for a firmware download via Ethernet.
<b>B</b> <b>Force</b> <b>Cold Start</b>		Pressing this button during a restart forces a cold start.
<b>RESET</b>		Forces a restart

## Maintenance

### Battery life

Lithium batteries usually have a life span of at least four years. The automation station automatically sends a system event in order to indicate a low charge. After the "Battery low" event there are several months of remaining life span.

### Battery change

To change the battery, remove the front cover. As long as the supply voltage is connected, the battery may be removed for unlimited time.



### Caution!

To prevent hardware damage by electrostatic discharge (ESD), a wrist strap with earth cable must be used during the battery change.

## Disposal



The unit contains electric and electronic components and must not be disposed of with domestic waste. Lithium battery, printed circuit board and housing must be disposed of separately

**The local and actual regulations must be observed.**

## Technical data

General device data	Operating voltage	AC 24 V ± 20 %	
	Safety extra-low voltage SELV		
	Protective extra-low voltage PELV	HD 384	
	Frequency	50/60 Hz	
	Current consumption	4 A	
	Power consumption	PXC00-U	45 VA
		PXC64-U	45 VA
PXC128-U		95 VA	
Internal fuse	Thermic, automatic reset		
Operating data	Processor	MOTOROLA Power PC 32 Bit	
	Memory space	FLASH	16 MByte
		SDRAM	32 MByte
		SRAM	2 MByte
	Data backup in case of power failure		
Applications, parameter (FLASH)	> 10 years		
Run-time data (battery)	> 4 years (battery)		
Ethernet interface (extension modules PXA30.N, PXA30.W...)	Interface type	100BaseTX, IEEE 802.3 compatible	
	Bit rate	10 / 100 Mbit/s, auto-sensing	
	Protocol	BACnet over UDP/IP	
	Connection	RJ45 socket, screened	
	Wiring	Cable type	Standard at least CAT5 UTP (Unshielded Twisted Pair) or STP (Shielded Twisted Pair)
Cable length		Max. 100m	
LONWORKS bus interface	Network	TP/FT-10	
	Baud rate	78 kBit/s	
	Protocol	BACnet	
	Interface chip	Echelon Processor TMPN3150B1AF	
	Wiring	Cable type	ConCab or CAT5
Cable length		See installation guide, CA110396	
Serial interface	Interface type	RS232	
	Baud rate / Data bits / Stop bit	57 600 bps / 8 / 1	
	Parity / Flow control	None / None	
	Wiring	Cable type	9-core standard screened cable
		Cable length	Max. 3m
P-bus interface (PXC64-U, PXC128-U)	Polling cycle at I/O modules	0.3 s	
	Transmission speed	62.5 kBaud	
	Signal level	DC +23 V and 0/-5 V	
	Wiring	Cross-section	Min. 3 x 0.75 mm <sup>2</sup>
		Cable length	Max. 50 m
		Cable length (special requirements)	Max. 200 m

Interface, room units	Interface type	PPS2	
	Supply class	4	
	PPS2 baud rate	4.8 kBit/s	
	Wiring	Cable type	4-core, twisted pair, unshielded
		Capacitance per unit length	Max. 56 nF/km
	Single cable length	Max. 125 m where A = 1.0 mm <sup>2</sup>	
Connecting cable	PXM10 or PXM20 / DESIGO TOOLSET	Max. 3 m	
Plug-in screw terminal	Power supply and signals	Stranded or solid conductors, 0.25 ... 2.5 mm <sup>2</sup> or 2 x 1.5 mm <sup>2</sup>	
	LONWORKS bus	Stranded or solid conductors, 2 x 1.0 mm <sup>2</sup>	
Housing protection standard	Protection standard to EN 60529	IP 30	
Protection class	Isolation protection class	II	
Ambient conditions	Operation	Class 3K5 to IEC 721	
	Temperature	0 ... 50 °C	
	Humidity	< 85 % rh	
	Transport	Class 2K3 to IEC 721	
	Temperature	- 25 ... 65 °C	
	Humidity	< 95 % rh	
Industry standards	Meets all requirements for B-AAC	BACnet Implementation Conformance Statement (PICS)	
	Product safety		
	Automatic electronic controls for household and similar use	EN 60730-1	
	Special requirements for energy controllers	EN 60730-2-11	
	Electromagnetic compatibility		
	Interference immunity	EN 61000-6-2	
	Emitted interference	EN 61000-6-2	
	Meets requirements for <b>CE</b> marking:		
	Electromagnetic compatibility	89/336/EEC	
	Low Voltage Directive	2006/95/EEC	
Dimensions	<i>See "Dimensions"</i>		
Weight	Without / with packaging	0.96 / 1016 kg	

## Connection terminals

### PXC64-U

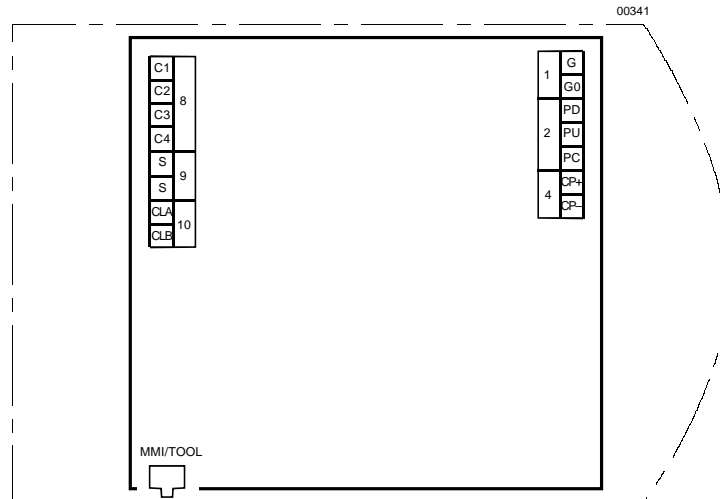

<b>G/G0</b>	Supply voltage AC 24 V/PELV
<b>PD</b>	P-bus Synchronisation cable
<b>PU</b>	Data transmission line, bi-directional
<b>PC</b>	Reference voltage DC 23 V (against G0)
<b>CP+/CP-</b>	PPS2 bus (for QAX... room operator units)
<b>CLA/CLB</b>	LONWORKS bus ( <i>inactive, if a PXA30-N... or PXA30-W... extension module for Ethernet is plugged in</i> )
<b>HMI/TOOL</b>	RJ45 socket on front cover (for PXM10 / PXM20 operator unit or DESIGO TOOLSET)

### PXC128-U

The PXA-C128-U includes a second P-bus:

- Terminals P-bus 1 PD1, PU1 and PC1
- Terminals P-bus 2 PD2, PU2 and PC2

### PXC00-U

The automation station PXC00-U does not have an active P-Bus interface

### Tool socket

Standard RJ45 tool socket for LONWORKS devices.

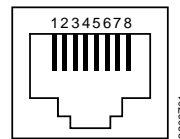

1	LONWORKS, Data A (CLA) *	5	Unoccupied
2	LONWORKS, Data B (CLB) *	6	Unoccupied
3	G0, GND	7	COM1/TxD
4	G/Plus	8	COM1/RxD

\*) The LONWORKS pins are inactive, if a PXA30-N... or PXA30-W... extension module for Ethernet is plugged in, and in the automation station PXC00-U)

## Connection diagrams

Connection of field devices: see mounting and installation manual for I/O modules and P-bus (CM2M8102).

**Dimensions**

**Front mounting**

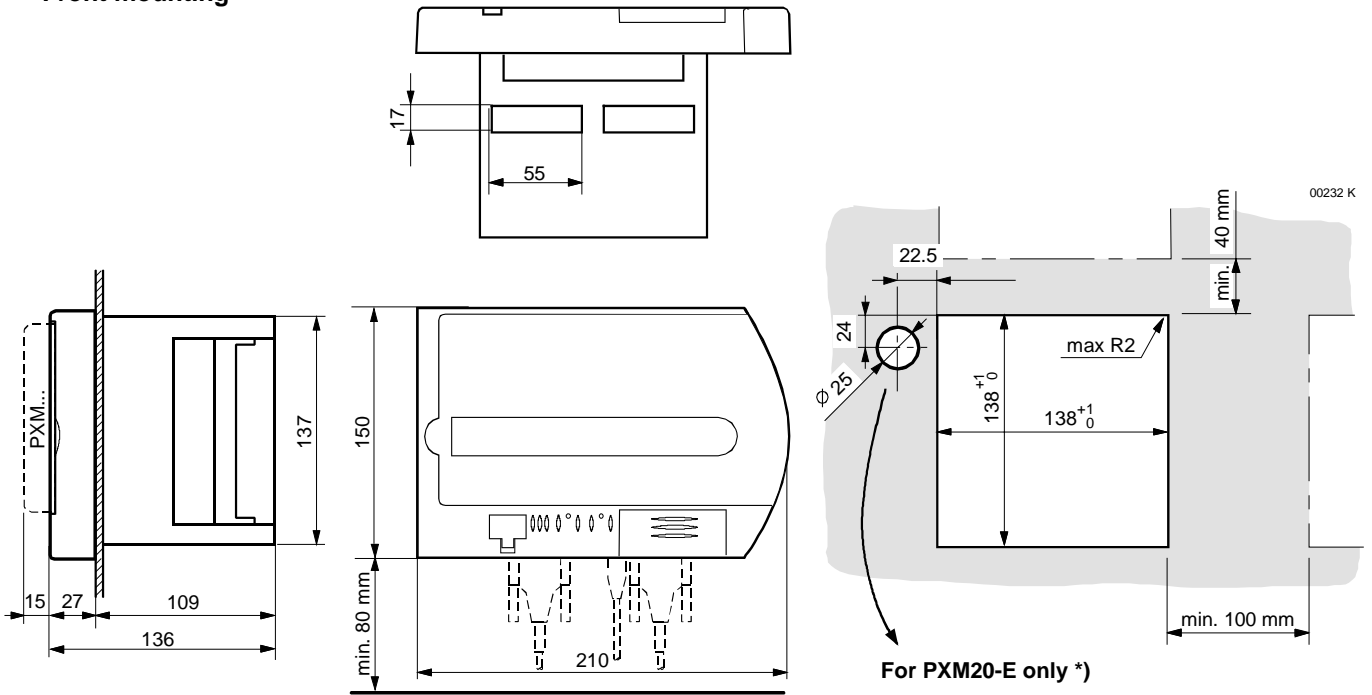

\*) This hole is required for the Ethernet cable when an operator unit PXM20-E is mounted on top of the automation station.

**Wall mounting**

